

Environmentally friendly systems for convenience stores



CO₂ refrigeration systems of the future

compSUPER XS ValuePack

More than 2400 systems in operation have positioned Advansor as the world's largest manufacturer of transcritical CO₂ refrigeration systems. The ValuePack range offers lucrative solutions over HFC systems. The primary target group for the ValuePack product is convenience stores and express formats. The price level of the ValuePack is fully competitive against HFC systems for a standard convenience store with medium (MT) and low temperature (LT) capacity. Although the price level is significantly below a traditional CO₂ booster system price, this does not interfere with Advansor's high quality levels and design requirements.

- Compact, easy-to-install and service friendly design
- Price competitive against HFC racks
- Same high quality as all other Advansor systems
- Green and environmentally friendly refrigerant – CO₂
- Future proof solution

Design

The ValuePack design is based on a standard compSUPER XS system which has been a part of Advansor's product portfolio since 2006. Only CO₂ is used as refrigerant. The ValuePack is a completely rethinking of the traditional Advansor way of designing CO₂ booster racks, where the compressors are placed in two layers; MT compressors at bottom and LT compressors at top. The ValuePack design is simpler with compressors in only one layer, the electrical panel above and the receiver left to the compressors. Combined with the use of K65 piping this leads to a very simple and compact design.

The ValuePack-series includes:

- MT suction accumulator
- Internal heat exchanger
- Oil management with reservoir and electronic oil controls
- Electrical panel with electronic controller
- MT compressor with integrated frequency inverter
- Safety switches and pressure relief valves
- Electronic gas-bypass valve and high pressure valve



compSUPER XS2x2VP



The design is compact and simple and available in four installation variations:

- Rack installed in weather-proof enclosure, with gas cooler connected and placed on top.
- Rack installed in weather-proof enclosure, with remotely installed gas cooler.
- Rack installed indoor in enclosure for noise reduction, with remotely installed gas cooler.
- Rack installed indoor without enclosure, with remotely installed gas cooler.



compSUPER XS2x2VP

ValuePack models:	XS2x0	XS2x1	XS2x2	XS3x0	XS3x1	XS3x2	XS3x2
# of compressors MT/LT	2/0	2/1	2/2	3/0	3/1	3/2	3/3
MT capacity [kW]*	15-55	12-46	15-40	30-75	30-75	30-75	30-75
LT capacity [kW]*	-	3-7	5-12	-	3-7	5-18	5-18
Receiver volume [L]	80	80	80	133	133	133	133
Mechanical connections							
Liquid line	1xCU5/8"	1xCU5/8"	1xCU5/8"	1xCU5/8"	1xCU5/8"	1xCU5/8"	1xCU5/8"
MT suction line	1xCU3/4"	1xCU3/4"	1xCU3/4"	1xCU3/4"	1xCU3/4"	1xCU3/4"	1xCU3/4"
LT suction line	-	1xCU1/2"	1xCU1/2"	-	1xCU1/2"	1xCU1/2"	1xCU1/2"
Frequency inverter	MT: Integrated (30-70Hz) -	MT: Integrated (30-70Hz) LT: Option	MT: Integrated (30-70Hz) LT: Option	MT: Integrated (30-70Hz) -	MT: Integrated (30-70Hz) LT: Option	MT: Integrated (30-70Hz) LT: Option	MT: Integrated (30-70Hz) LT: Option
Electrical connection	3x400V+N/50Hz	3x400V+N/50Hz	3x400V+N/50Hz	3x400V+N/50Hz	3x400V+N/50Hz	3x400V+N/50Hz	3x400V+N/50Hz
Length [mm]**	2000	2000	2000	2800	2800	2800	3000
Width [mm]**	800	800	800	800	800	800	800
Height [mm]**	1400	1400	1400	1900	1900	1900	1900
Weight [kg]**	1100	1150	1200	1400	1450	1500	2200

*MT and LT capacities stated at respectively -10°C and -32°C evaporation/32°C ambient

**Dimensions and weight excluding weather-proof/noise reducing enclosure.

Standard configuration:

- High-quality semi-hermetic compressors
- Rack installed in weather-proof and sound reducing enclosure with gas cooler on top
- Gas cooler with speed-controlled fans
- One frequency controlled MT compressor
- Electrical panel incl. electronic controller
- K65 piping
- Design pressure
 - 30 bar on low temperature suction side
 - 52 bar on medium temperature suction side
 - 60 bar/80 bar on receiver
 - 120 bar on high pressure side



compSUPER XS2x2VP

Options:

- Heat recovery
- Rack installed in enclosure
- Gas cooler installed remotely, delivered loose
- One frequency controlled LT compressor



compSUPER PKE Housing (XS 3x2 VP)

compSUPER SIGMA ValuePack

Combining the compSUPER XS ValuePack concept with the most sophisticated compSUPER Sigma concept has led to the compSUPER SIGMA ValuePack range. The SIGMA ValuePack range provides single pack solutions with integrated capacity for medium (MT) and low temperature (LT) refrigeration, air conditioning (AC) and heating. The SIGMA ValuePack accommodates low investment cost while satisfying all cooling and heating requirements of the store. This is a new opportunity for saving money, time, and only concentrate on core sales.

- All-in-one unit – integrated cooling, freezing, air conditioning and heating
- Compact, easy-to-install and service friendly design
- Energy efficient performance in hot climate
 - Electrical savings: Southern Europe 6-7% (11% including heat recovery)
- Low investment cost
- Same high quality as all other Advansor systems
- Green and environmentally friendly refrigerant – CO₂
- Future proof solution

SIGMA concept

For small sized stores it often makes sense to combine all cooling and heating demands in one integrated solution. The compSUPER SIGMA ValuePack system is based on a standard CO₂ booster system serving medium (MT) and low temperature (LT) loads. In a very simple way air condition (AC) capacity and heat capacity is added to the system.

AC capacity is integrated by adding an AC evaporator (refrigerant/glycol) between the high pressure valve (HP-valve) and the receiver. The AC capacity is controlled by modulating receiver pressure, by-pass and glycol-side.

For heating purpose, a heat recovery unit is added on the high pressure side. Furthermore, a "heat pump function" can be added by integrating an evaporator in the air cooled gas cooler. This heat exchanger absorbs heat from ambient air when more heat is needed in the store.

With an addition of integrated parallel compression (IT), the system ensures very high efficiency during summer operation with AC as well as winter operation with heat recovery.

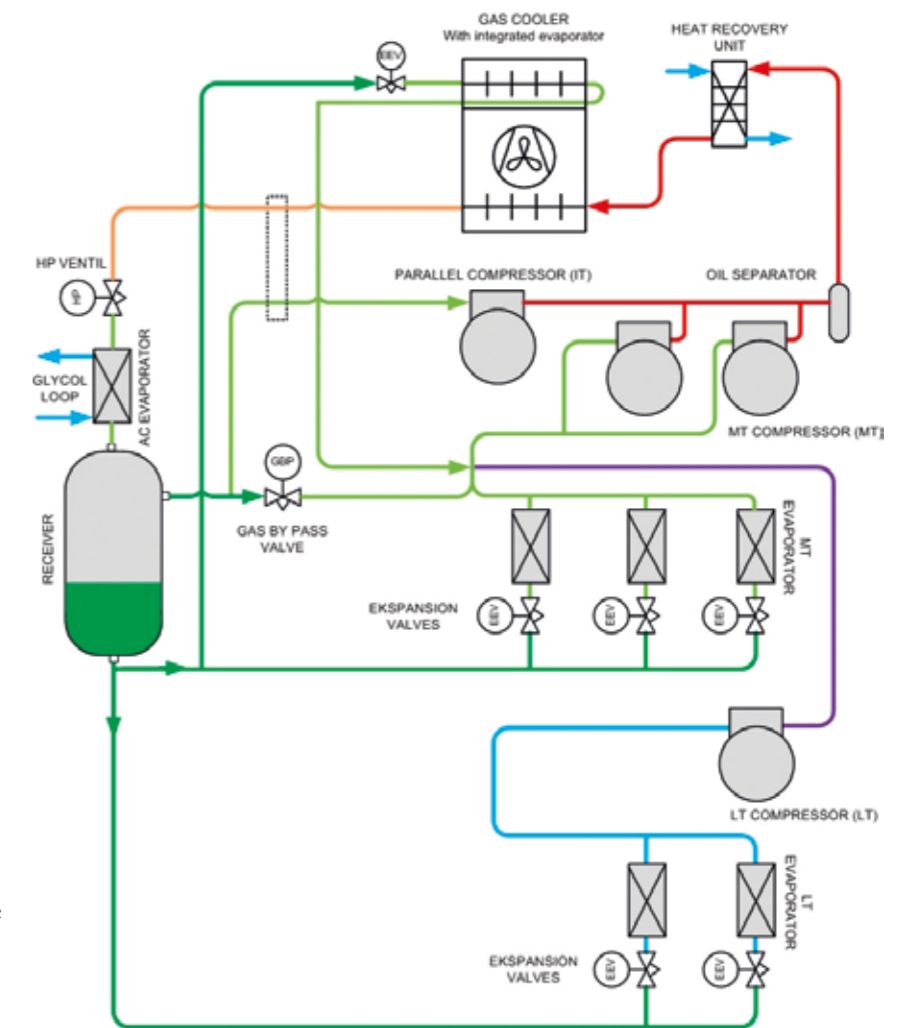

SIGMA ValuePack models:	XS 2+1x1	XS 2+1x2	XS 3+1x1	XS 3+1x2
# of compressors MT+IT/LT	2+1/1	2+1/2	3+1/1	3+1/2
MT capacity [kW]*	25-55	25-55	40-70	40-70
AC capacity [kW]*	10-20	10-20	20-40	20-40
LT capacity [kW]*	3-7	5-12	3-10	5-15
Receiver volume [L]	80/133	80/133	133	133
Mechanical connections				
Liquid line	1xCU5/8"	1xCU5/8"	1xCU5/8"	1xCU5/8"
MT suction line	1xCU3/4"	1xCU5/8"	1xCU5/8"	1xCU5/8"
LT suction line	1xCU1/2"	1xCU1/2"	1xCU1/2"	1xCU1/2"
Frequency inverter	MT: Integrated (30-70Hz) IT: External (30-70Hz) LT: option	MT: Integrated (30-70Hz) IT: External (30-70Hz) LT: option	MT: Integrated (30-70Hz) IT: External (30-70Hz) LT: option	MT: Integrated (30-70Hz) IT: External (30-70Hz) LT: option
Electrical connection	3x400V+N/50Hz	3x400V+N/50Hz	3x400V+N/50Hz	3x400V+N/50Hz
Length [mm]**	2800	2800	3000	3000
Width [mm]**	800	800	800	800
Height [mm]**	1400/1900	1400/1900	1900	1900
Weight [kg]**	1500	1550	2200	2250

*MT and LT capacities stated at respectively -8°C and -30°C evaporation/32°C ambient air temperature
 AC capacities stated at glycol loop 7/12°C
 **Dimensions and weight excluding enclosure.

Standard configuration:

- High-quality, semi-hermetic compressors
- One frequency controlled MT compressor
- One frequency controlled IT compressor
- Heat recovery
- Air conditioning (AC)
- Design pressure
 - 30 bar on low temperature suction side
 - 52 bar on medium temperature suction side
 - 60 bar/80 bar on receiver and air conditioning
 - 120 bar on high pressure side
- Gas cooler with speed-controlled fans
- Electronic controllers
- High safety level with pressure relief valves and pressure switches and intelligent controls
- Smaller models installed in weather-proof and sound reducing enclosure with integrated gas cooler

Options:

- Integrated evaporator in gas cooler (air-to-water "heat pump function")
- Rack installed in cabinet
- One frequency controlled LT compressor



compSUPER XS2+1x1 Sigma



compSUPER PKE Housing (XS 2+1x2 VP)



Advansor A/S
Bautavej 1A · DK-8210 Aarhus V · T. +45 72 17 01 74
info@advansor.dk · advansor.dk

ADVANSOR TM
by Hillphoenix